

4

3

2

1

D

D

C

C

B

B

A

A

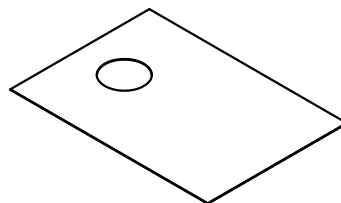
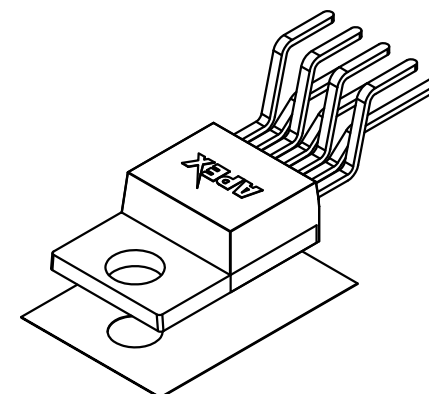
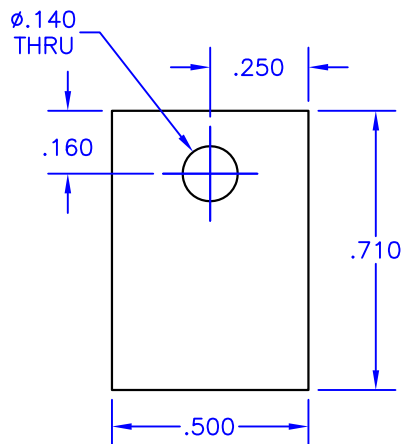

NOTES:

1. Unless otherwise noted, all dimensions are in inches.
2. Film Material: .002 thick Kapton® MT
Dielectric strength – 5200 VAC/mil
3. Interface Material: .0005 thick phase-change thermal compound, both sides.
Maximum shipping & storage temperature – 40°C
Reflow temperature – 60°C
Maximum recommended service temperature – 200°C
4. Thermal impedance: .201 °C-in²/W (1.30 °C-cm²/W) @ 20psi
5. Thermal washers shall be packaged in quantities of 10 with oversize separators between them.
6. Used with TO220 packages (Apex designators: CD & CX).
7. Power Devices part no. KA-070-050-APX

TOLERANCES – UNLESS OTHERWISE SPECIFIED	
.XX	= ±.01
.XXX	= ±.005
ANG.	= ±.5°



TITLE THERMAL WASHER, TO220				PART NO. TW14	
SUBJECT MECHANICAL DRAWING					
ENG. D-M	TECH/DWN. P.ECK	DCA 80339	SHL OF 1 1	FILENAME TW14	REV DATE E 03NOV08

4

3

2

1